

Product Evaluation

RC483 | 0121

Engineering Services Program

The following product has been evaluated for compliance with the wind loads specified in the International Residential Code (IRC) and the International Building Code (IBC).

This product evaluation is not an endorsement of this product or a recommendation that this product be used. The Texas Department of Insurance has not authorized the use of any information contained in the product evaluation for advertising, or other commercial or promotional purpose.

This product evaluation is intended for use by those individuals who are following the design wind load criteria in Chapter 3 of the IRC and Section 1609 of the IBC. The design loads determined for the building or structure shall not exceed the design load rating specified for the products shown in the limitations section of this product evaluation. This product evaluation does not relieve a Texas licensed engineer of his responsibilities as outlined in the Texas Insurance Code, the Texas Administrative Code, and the Texas Engineering Practice Act.

For more information, contact TDI Engineering Services Program at (800) 248-6032.

Evaluation ID: RC-483

Effective Date: January 1, 2021

Re-evaluation Date: January 2025

Product Name: Minimum 26-Gauge Steel Low Rib X Roof Panels Installed Over Steel Purlins or a Plywood Deck

Manufacturer: Whirlwind Building Components
8234 Hansen Road
Houston, TX 77075
(713) 946-7140

General Description:

The Low Rib X metal roofing panels have 36" of coverage. The metal roof panels have a 3/4" rib height at 6" on center. The metal roof panels are manufactured from minimum 26-gauge Galvalume coated steel that conform to ASTM A792, Grade 80, with a minimum yield strength of 80,000 psi. The metal roofing panels can be painted with Kynar 500 Fluoropolymer finish coating.

Limitations:

Roof Framing: The metal roofing panels may be installed over one of the following types of roof framing:

Minimum 15/32" plywood roof deck

Minimum 16-gauge (0.056") steel purlins

New Roof Framing Attachment: The roof framing must meet or exceed the uplift requirements of the IRC or IBC and must be installed as required for resistance to wind loads.

Design Wind Pressures: The design pressure uplift load resistance must be as specified in Tables 1-2.

Roof Slope: The metal roofing panels may be installed on roofs with a roof slope as low as 3:12. If applied lap sealant is used, then the minimum roof slope is 1/2: 12.

Table 1

Attachment of Minimum 26-Gauge Low-Rib X Steel Roofing Panels to minimum 15/32" plywood Roof Deck

| Design Wind Pressure (psf) | Attachment of Roof Panel to 15/32" Plywood |
|----------------------------|--|
| -56.0 psf | Fastener Pattern No. 1 @ 24" o.c. |
| -131.0 psf | Fastener Pattern No. 2 @ 12" o.c. |

Table 2

Attachment of Minimum 26-Gauge Low-Rib X Steel Roofing Panels to 16-Gauge Steel Purlins

| Design Wind Pressure (psf) | Attachment of Roof Panel to 16 Gauge Steel Purlins |
|----------------------------|--|
| -135.3 psf | Fastener Pattern No. 1 with purlins spaced at 24" o.c. |
| -121.0 psf | Fastener Pattern No. 1 with purlins spaced at 30" o.c. |
| -106.7 psf | Fastener Pattern No. 1 with purlins spaced at 36" o.c. |
| -92.4 psf | Fastener Pattern No. 1 with purlins spaced at 42" o.c. |
| -78.1 psf | Fastener Pattern No. 1 with purlins spaced at 48" o.c. |
| -63.8 psf | Fastener Pattern No. 1 with purlins spaced at 54" o.c. |
| -49.5 psf | Fastener Pattern No. 1 with purlins spaced at 60" o.c. |

Installation over an Existing Roof Covering: Installation over an existing roof covering is limited to a maximum of one existing layer of composition shingles, wood shingles or shakes, built-up roofing, or roll roofing applied over an existing, solid roof deck of minimum 15/32" plywood. Note: Inspection of the existing roof deck must be made prior to the installation of the roof panels. The condition of the existing roof deck must be acceptable to receive the metal roofing panels before the metal roofing panel installation proceeds. NOTE: Underlayment is not required to be installed.

Installation:

General: The metal roofing panels must be installed in accordance with the manufacturer's recommended installation instructions and this evaluation report.

Panels: The metal roofing panels must be secured to the roof framing as specified in Tables 1-2 and in accordance with this section.

Steel Purlins: The steel purlin roof framing must meet or exceed the uplift requirements of the IRC or IBC and must be installed as required for resistance to wind loads.

Underlayment: For installations over a solid deck, a minimum of one layer of No. 30 (Type II) asphalt felt must be used. The underlayment used must comply with one or more of the following: ASTM D 226, ASTM D 4869, or ASTM D 1970. The underlayment must be installed with 6" side laps and 3" end laps. The underlayment must be applied with corrosion resistant roofing nails in accordance with the manufacturer's installation instructions. Fasteners must be applied along the overlaps a maximum of 36" on center.

Attachment of Metal Roof Panels to the Roof Deck: The metal roofing panels must be secured to the roof framing in one of the following ways:

Roofing Panels to Plywood Deck: Minimum No. 10-15 x 1-1/2" long, HiLo Woodgrip screws with washers or approved equal. The fasteners must be long enough to ensure a minimum penetration of 1/4" below the roof deck. (Note: If the metal roofing panels are installed over an existing roof covering, then the fastener length must be increased so that the fasteners are long enough to ensure a minimum penetration of 1/4" below the existing plywood roof decking.) The required fastener pattern and maximum allowable spacing of the fastener lines is specified in Table 1. Refer to Figure 1 for illustrations of the fastener patterns.

Roofing Panels to the Steel Purlins: Minimum No. 12-14 x 1-1/4" long, Ultimate HWH self-drilling screws with integral washers or approved equal. The fasteners must be long enough to ensure a minimum penetration of 3 pitches of thread below the steel hat purlins. The required fastener pattern, the maximum allowable spacing of the fastener lines, and the attachment of the purlins to the roof framing is specified in Table 2. Refer to Figure 2 for illustrations of the fastener patterns.

Panel Side Laps: The panels are stitched together with minimum 1/4-14 x 7/8" long hex head screws with a 5/8" dome washer. The fasteners must be spaced 20" on center along the length of the side lap.

Alternative Fasteners: Alternative fasteners of equal or greater strength may be substituted.

Trims, Closures, and Accessories: Components, such as the eave trim, rake trim, ridge trim, hip trim, and valley trim must be installed as required by the manufacturer.

Note: Keep the manufacturer's installation instructions available on the job site during the installation. Use corrosion resistant fasteners as specified in the IRC and the IBC.

FASTENER PATTERN #1

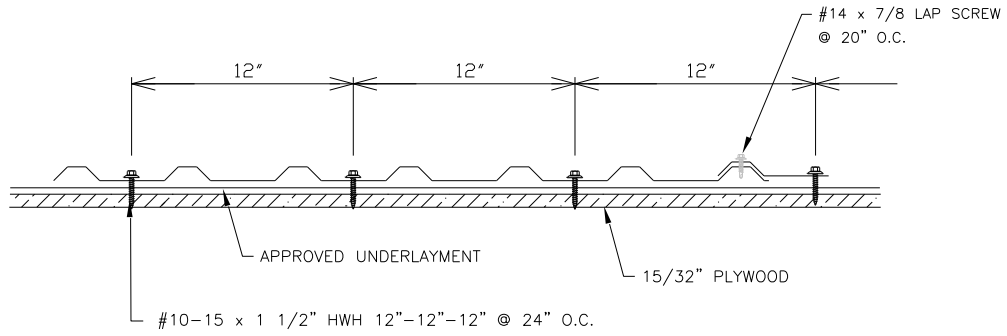

FASTENER PATTERN #2

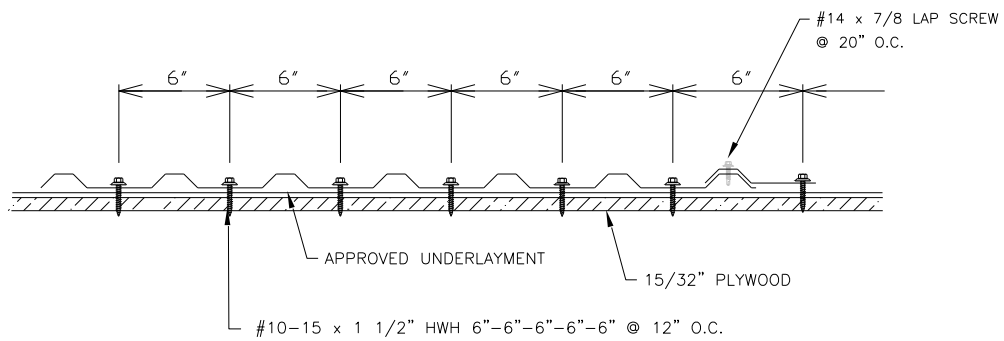

Figure 1. Low Rib X Metal Roofing Panel Secured to a 15/32" Plywood Deck

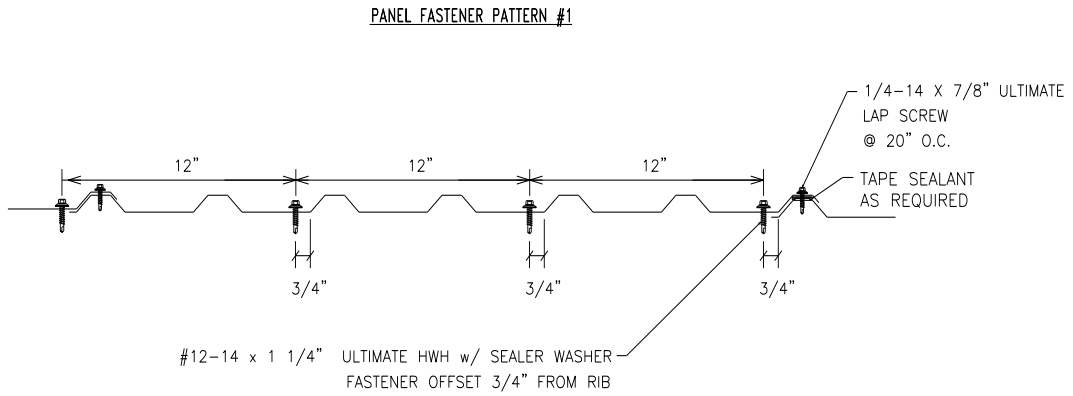

Figure 2. Low Rib X Metal Roofing Panel Secured to 16-Gauge Steel Purlins